



# A SERIES

## POWERSTREAM™ ELASTOMER COUPLINGS

# A SERIES

- A – Retaining Ring with Locking Feature
- B – Wrap-Around Elastomeric Insert
- C – Hubs (Blank or Bored)
- D – Anti-Corrosion Treatment

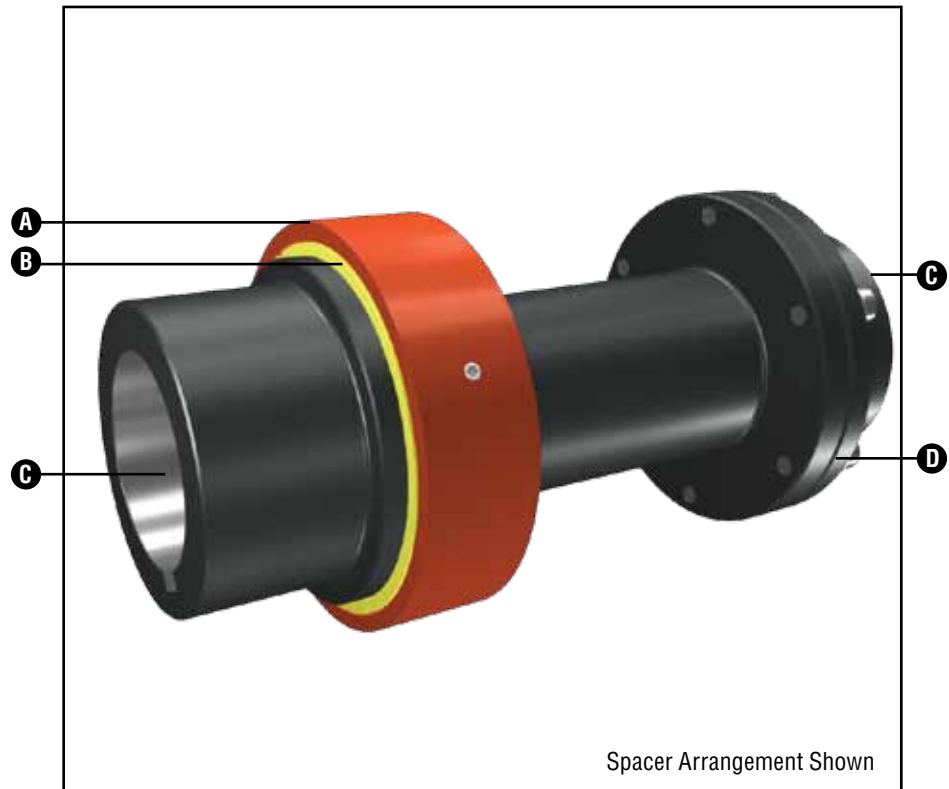

### Product Description

A Series couplings provide a solution to one of the most persistent and troublesome problems facing maintenance personnel, periodic coupling failure and the downtime and expense that goes with it. If a new insert is needed, a replacement can be installed in minutes, without moving either the prime mover or the driven equipment.

The A Series is the simplest construction of all our couplings. The overall design is compact and can be supplied as a close coupled or spacer design.

**Close Coupled Arrangement:** Two identical hubs made of high strength steel, each with six or eight teeth, depending on size. The split insert, which is made of specially compounded Urethane, fits over the hub teeth. The retaining ring is made of steel, located with two setscrews. The close coupled arrangement requires no nuts or bolts.

**Spacer Arrangement:** A close coupled hub and a spacer hub. One end of the spacer piece has six or eight teeth, depending on size with the other end flanged. All of these components are made of high strength steel. The split insert, which is made of specially compounded Urethane, fits over the hub / spacer teeth. The retaining ring is made of steel, located with two setscrews. Bolts are supplied to assemble spacer to spacer hub.

### Design Features

- Easy to install
- Urethane insert is resistant to most chemicals and oils
- Standard insert: -40°C to 80°C / -40°F to 180°F
- High temperature inserts: up to 150°C / 300°F
- No lubrication or maintenance
- Can rotate hubs independently for motor test
- No metal-to-metal contact
- Large bore and torque capacity
- Horizontal and vertical operations, in either direction, using standard inserts and retaining rings
- High misalignment capability
- Hubs can be supplied either finish machined or with blank bores
- Ideally suited for a vast range of applications in a wide variety of industries
- The spacer arrangement meets ANSI requirements



# A SERIES

POWERSTREAM™

## ELASTOMER COUPLINGS

### Close Coupled Dimensions (mm)

Coupling Size	A	B	C (1)		D	E (3)		F (4)	
			Rect. Key			DBSE			
	mm	mm	mm	mm (2)	mm	mm	mm	mm	
A00C	63	52	41	23	28	16.5	1.5		
A01C	80	65	51	37	35	21.7	1.5		
A02C	107	76	61	46	43	31.7	1.5		
A03C	139	103	85	53	56	42	3		
A04C	177	130	108	75	71	52	3		
A05C	225	154	126	98	92	60.2	3		
A06C	265	186	151	119	110	68.4	3		
A07C	306	222	182	146	130	76.4	3		
A08C	363	263	213	172	152	86.4	3		

### Spacer Dimensions (mm)

Coupling Size	A	B	C Max (1)		D	E				G	H	J	K
			Rect. Key			DBSE (3)			Min (4)				
	mm	mm	mm	mm (2)	mm	mm	mm	mm	mm	mm	mm	mm	mm
A01S	80	65	51	37	35	100	140	180	57	45	46	69	105
A02S	107	76	61	46	43	100	140	180	62	55	65	90	130
A03S	139	103	85	53	56	100 (4)	140	180	88	62	80	112	152
A04S	177	130	108	75	71	100 (4)	140	180	96	70	90	131	179
A05S	225	154	126	98	92		140	180	111	95	127	181	222
A06S	265	186	151	119	110		140 (4)	180	117	115	155	223	272

### Technical Data (Metric)

Coupling Size	Standard Insert		High Torque Insert		Speed	Mass (5)		Misalignment		
	Rating	Max Continuous Torque	Rating	Max Continuous Torque		Close Coupled	Spacer	Axial	Parallel	Angular
	kW/1000rpm	Nm	kW/1000rpm	Nm		rpm	kg		mm	mm
A00C	6	57	8	78	9600	1.1		0.5	0.5	2
A01C/S	11	107	15	142	7800	2.1	4	1.0	1.0	2
A02C/S	30	285	40	377	5900	4	7.7	1.0	1.0	2
A03C/S	60	569	78	740	4400	9.2	15	1.5	1.0	2
A04C/S	120	1140	160	1540	3400	19	25.7	1.5	1.5	1.3
A05C/S	300	2875	400	3800	2700	35.4	52.1	2.0	1.5	1.3
A06C/S	480	4600	650	6200	2200	59.7	90.3	2.0	1.5	1.3
A07C	960	9200	1160	11100	1900	98.2		2.0	1.5	1
A08C	1800	17200	2200	21000	1600	163		2.0	1.5	1

Notes:

- 1 Maximum bore based on standard ISO key dimensions
- 2 Maximum bore for shafts extending under the close coupled teeth
- 3 Preferred standard DBSE
- 4 Dependant on shaft size – Please refer to Kselect or John Crane
- 5 Mass at minimum DBSE with unbored hubs



# A SERIES

POWERSTREAM™

ELASTOMER COUPLINGS

## Close Coupled Arrangement

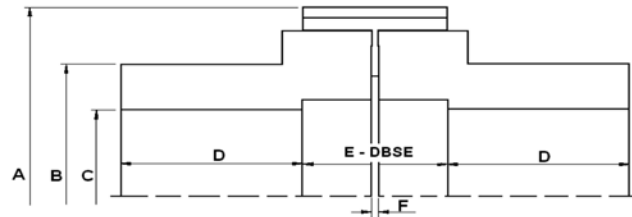

## Spacer Arrangement

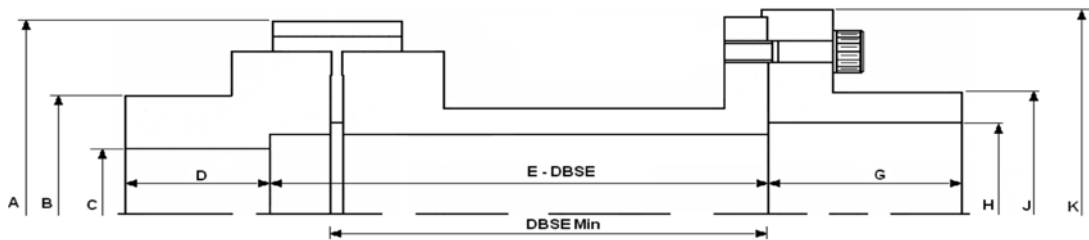

## Selection Procedure (Metric)

- 1 – Select appropriate load factor from table SF1
- 2 – Select appropriate service factor from table SF2
- 3 – Calculate coupling rating from:

$$R = \frac{kW \times 1000 \times SF2}{N}$$

Where: kW = Driver rated Power (kW)  
N = speed (rpm)

- 4 – Select a coupling with the same or higher rating
- 5 – Confirm that the hub bore capacity is suitable
- 6 – Confirm that the peak torque capability is suitable for the application
- 7 – Check speed capability
- 8 – Specify distance between shaft ends (DBSE)
- 9 – Ensure that the ambient temperature is between -40°C to 80°C (180°F) for standard inserts and 150°C (300°F) for high temperature

## Selection Procedure (Imperial)

- 1 – Select appropriate load factor from table SF1
- 2 – Select appropriate service factor from table SF2
- 3 – Calculate coupling rating from:

$$R = \frac{HP \times 100 \times SF2}{N}$$

Where: HP = Driver rated Power (horsepower)  
N = speed (rpm)

- 4 – Select a coupling with the same or higher rating
- 5 – Confirm that the hub bore capacity is suitable
- 6 – Confirm that the peak torque capability is suitable for the application
- 7 – Check speed capability
- 8 – Specify distance between shaft ends (DBSE)
- 9 – Ensure that the ambient temperature is between -40°C to 80°C (180°F) for standard inserts and 150°C (300°F) for high temperature



Kselect is an internet based selection program for A Series. This selection program provides all necessary technical data including inertias and torsional stiffness.

Visit [www.johncrane.com](http://www.johncrane.com).



# A SERIES

POWERSTREAM™

## ELASTOMER COUPLINGS

### Close Coupled Dimensions (Inches)

Coupling Size	A	B	C (1)		D	E (3)	F (4)
	in	in	Square Key			in	DBSE
			in	in (2)	in		in
A00C	2.48	2.04	1.44	0.938	1.12	0.65	0.06
A01C	3.15	2.55	1.75	1.38	1.38	0.86	0.06
A02C	4.21	3	2.18	1.69	1.69	1.25	0.06
A03C	5.47	4.05	2.88	1.88	2.19	1.66	0.12
A04C	6.97	5.1	3.75	2.69	2.81	2.05	0.12
A05C	8.86	6.07	4.5	3.44	3.62	2.37	0.12
A06C	10.4	7.31	5.38	4.25	4.31	2.69	0.12
A07C	12	8.75	6.38	5.13	5.12	3	0.12
A08C	14.3	10.4	7.5	6.13	6	3.4	0.12

### Spacer Dimensions (Inches)

Coupling Size	A	B	C Max (1)		D	E			G	H	J	K
	in	in	Square Key			DBSE (3)		Min (4)				
			in	in (2)	in	in	in					
A01S	3.15	2.55	1.75	1.38	1.38	3.5	5	2.24	1.77	1.88	2.72	4.13
A02S	4.21	3	2.18	1.69	1.69	3.5	5	2.43	2.17	2.31	3.54	5.12
A03S	5.47	4.05	2.88	1.88	2.19	3.5 (4)	5	3.45	2.44	3	4.41	5.98
A04S	6.97	5.1	3.75	2.69	2.81		5	3.78	2.76	3.44	5.16	7.05
A05S	8.86	6.07	4.50	3.44	3.62		5 (4)	4.43	3.74	4.67	7.13	8.74
A06S	10.4	7.31	5.38	4.25	4.31		5 (4)	4.68	4.53	5.75	8.78	10.71

### Technical Data (Imperial)

Coupling Size	Standard Insert		High Torque Insert		Speed	Mass (5)		Misalignment		
	Rating	Max Continuous Torque	Rating	Max Continuous Torque		Close Coupled	Spacer	Axial	Parallel	Angular
	hp/100 rpm	lb - in	hp/100 rpm	lb - in	rpm	lb		in	in	Degree
A00C	0.8	504	1.1	690	9600	2.5		0.02	0.02	2
A01C/S	1.5	945	2	1260	7800	4.6	9	0.04	0.04	2
A02C/S	4	2525	5	3340	5900	8.7	17	0.04	0.04	2
A03C/S	8	5040	10	6550	4400	20.3	33	0.06	0.04	2
A04C/S	16	10080	22	13680	3400	41.9	57	0.06	0.06	1.3
A05C/S	40	25460	53	33400	2700	78	114	0.08	0.06	1.3
A06C/S	65	40700	88	55300	2200	132	198	0.08	0.06	1.3
A07C	129	81300	156	98300	1900	217		0.08	0.06	1
A08C	242	152500	294	185300	1600	360		0.08	0.06	1

Notes:

- 1 Maximum bores shown are based on AGMA square key dimensions
- 2 Maximum bore for shafts extending under the close coupled teeth
- 3 Preferred standard DBSE
- 4 Dependant on shaft size – Please refer to Kselect or John Crane
- 5 Mass at minimum DBSE with unbored hubs



# A SERIES

## POWERSTREAM™ ELASTOMER COUPLINGS

### Load Factor SF1

<b>AGITATORS</b>	Induced Draft without Dampner Control..... H	Kick-outs ..... A	Press Roll ..... H
Pure liquids ..... U		Manipulators ..... H	Reel ..... A
Liquids & Solids ..... A	<b>FEEDERS</b>	Merchant Mills..... H	Stock Chests ..... A
Liquid – Variable Density..... A	Apron, Belt, Disc, Screw..... U	Pusher Rams..... A	Suction Roll..... A
	Reciprocating ..... H	Reel Drives ..... A	Washers & Thickeners ..... A
<b>BLOWERS</b>	<b>HAMMER MILLS</b> ..... A	Reel Drums ..... A	Winders ..... A
Centrifugal ..... U	<b>LUMBER INDUSTRY</b>	Reelers ..... H	
Lobe ..... A	Barkers – Drum Type..... H	Rod and Bar Mills..... H	<b>PUMPS</b>
Vane ..... U	Edger Feed..... H	Roughing Mill Delivery Table..... H	Centrifugal..... U
<b>CLAY &amp; STONE WORKING</b>	Live Rolls..... H	Runout Tables ..... A	Reciprocating Single Acting
<b>MACHINERY</b> ..... H	Log Haul – Incline ..... H	Saws, Hot and Cold ..... A	1 or 2 Cylinders..... H
	Log Haul – Well Type..... H	Screwdown Drives ..... H	Double Acting ..... H
<b>COMPRESSORS</b>	Off Bearing Rolls ..... H	Slitters ..... H	Rotary, Gear, Lobe, Vane..... A
Centrifugal ..... U	Planer Feed Chains ..... A	Slab Mills..... H	
Lobe ..... A	Planer Floor Chains ..... A	Soaking Pit Cover Drives..... H	<b>ROTARY MILLS</b>
Reciprocating-Multi-Cylinder ..... H	Planer Tilting Hoist ..... A	Straighteners ..... A	Ball ..... H
<b>CONVEYORS – Light Duty Uniformly Fed</b>	Slab Conveyor ..... U	Tables, Transfer & Runout..... A	Dryers & Coolers..... H
Apron, Bucket, Chain, Flight,	Sorting Table ..... U	Thrust Block ..... H	Hammer ..... H
Screw ..... U	Trimmer Feed ..... A	Traction Drive ..... H	Kilns ..... H
Assembly Belt..... U		Tube Conveyor Rolls ..... A	Pebble & Rod ..... H
Oven ..... A	<b>METAL MILLS</b>	Wire Drawing..... A	Pug ..... H
	Draw Bench – Carriage..... H		Tumbling Barrels ..... H
<b>CONVEYORS – Heavy Duty Not Uniformly Fed</b>	Draw Bench – Main Drive..... H	<b>MIXERS</b>	
Apron, Bucket, Chain, Flight,	Forming Machines..... H	Concrete ..... A	<b>RUBBER INDUSTRY</b>
Oven ..... A	Slitters ..... H	Drum Type..... A	Mixed – Banbury ..... H
Assembly Belt..... U	Table Conveyors		Rubber Calendar..... H
Reciprocating, Shaker ..... H	Non-Reversing ..... H	<b>PAPER MILLS</b>	Rubber Mill (2 or more) ..... H
<b>CRANES AND HOISTS (Note)</b>	Reversing ..... H	Barker, Auxilliaries, Hydraulic.... H	Sheeter ..... H
Main Hoists, Reversing ..... H	Wire Drawing &	Barker, Mechanical ..... H	Tire Building Machines..... H
Skip Hoists, Trolley & Bridge	Flattening Machine ..... A	Barking Drum Spur Gear Only... H	Tire & Tube Press Openers..... U
Drives ..... A	Wire Winding Machine ..... A	Beater & Pulper ..... A	Tubers & Strainers ..... H
Slope ..... A		Bleacher..... U	
<b>CRUSHERS</b>	<b>METAL ROLLING MILLS</b>	Calenders..... H	<b>SEWAGE DISPOSAL EQUIPMENT</b>
Ore Stone ..... H	Coilers, Hot Mill..... A	Chippers ..... A	Bar Screens ..... U
<b>ELEVATORS (Note)</b>	Coilers, Cold Mill ..... U	Coaters ..... U	Chemical Feeders ..... U
Bucket ..... A	Cold Mills ..... A	Couch Roll..... A	Dewatering Screens ..... U
Centrifugal & Gravity Discharge. U	Cooling Beds ..... A	Cutters, Platers..... H	Grit Collectors ..... U
Escalators ..... U	Door Openers ..... A	Cylinders ..... A	Scum Breakers ..... U
Freight ..... H	Draw Benches ..... H	Disc Refiners ..... A	Slow or Rapid Mixers..... U
<b>FANS</b>	Edger Drives..... A	Dryers..... A	Sludge Collectors ..... U
Centrifugal ..... U	Feed Rolls, Reversing Mills..... H	Felt Stretcher ..... U	Thickeners..... U
Cooling Towers..... A	Furnace Pushers..... A	Felt Whipper ..... H	Vacuum Filters..... U
Forcing Drafts..... A	Hot Mills ..... H	Line Shaft ..... U	
	Ingot Cars..... A	Log Haul ..... H	
		Pulp Grinder ..... A	

### Service Factor SF2

PRIME MOVER	LOAD FACTOR FOR DRIVEN MACHINE		
	U	A	H
ELECTRIC, HYDRAULIC MOTORS & TURBINES	1.00	1.25	1.75
PISTON ENGINES: 4 CYLINDERS & ABOVE	1.50	1.75	2.25
PISTON ENGINES: 1 – 3 CYLINDERS	2.00	2.25	2.75

Note: If the coupling is subject to more than 25 starts per hour, add 0.75 to SF2



# A SERIES

## POWERSTREAM™ ELASTOMER COUPLINGS

### Easy to Install

After hubs (1) and (2) and retaining ring (4) are installed on the shaft, the teeth are aligned parallel to each other, spaced apart according to Table 1 below.

Once installed, the hubs never need to be moved again. The Urethane insert (3) can then be installed in the slots formed by the parallel teeth.

When the insert is in position, align the pin in the retaining ring with the slot in the insert, slide the retaining ring (4) onto the Urethane insert and tighten the setscrews into the counter-bores in the insert. Centrifugal force will expand the elastic insert to fit tightly to the inside of the retaining ring, improving system integrity.

To disassemble, loosen the setscrews in the retaining ring and remove the ring. The insert can then be quickly and easily removed and replaced. No special tools are needed.

The assembly and disassembly of the spacer arrangement follow the same procedure with the additional process of securing the spacer to the spacer hub with bolts. The tightening torques for each size are shown in Table 2.

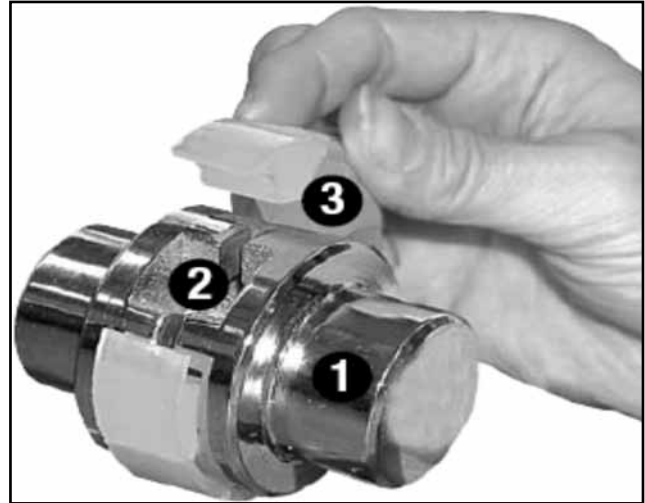

Table 1

Coupling Size	Gap Between Teeth
A00#–A02#	0.4mm / 0.016in
A03#–A08#	3mm / 0.12in

Table 2

Size	Tightening Torque	
	Nm	lb <sup>2</sup> in
A10S	19	170
A20S	19	170
A30S	54	480
A40S	100	880
A50S	100	880
A60S	230	2000



For your nearest John Crane facility, please contact one of the locations below.

**North America**  
**Global Headquarters**  
 Morton Grove, IL USA  
**1-800-SEALING**  
 Tel: 1-847-967-2400  
 Fax: 1-847-967-3915

**Europe**  
 Slough, UK  
 Tel: 44-1753-224000  
 Fax: 44-1753-224224

**Latin America**  
 São Paulo, Brazil  
 Tel: 55-11-3371-2500  
 Fax: 55-11-3371-2599

**Middle East & Africa**  
 Dubai, United Arab Emirates  
 Tel: 971-481-27800  
 Fax: 971-488-62830

**Asia Pacific**  
 Singapore  
 Tel: 65-6518-1800  
 Fax: 65-6518-1803



If the products featured will be used in a potentially dangerous and/or hazardous process, your John Crane representative should be consulted prior to their selection and use. In the interest of continuous development, John Crane Companies reserve the right to alter designs and specifications without prior notice. It is dangerous to smoke while handling products made from PTFE. Old and new PTFE products must not be incinerated. ISO 9001 and ISO 14001 Certified, details available on request.