

The seals are used in all rotating machines in the relevant industrial sectors.

The LAR type is designed for internal fittings, compatible with a retaining sleeve, whilst the LBR type is designed for external fitting.



- Slightly corrosive chemicals
- Monobloc for rapid installation
- Compatible seal types: PRR, EPR, EPE
- **Temperature:** -40 °C to 180 °C (depending on material choice)
- **Pressure:** up to 10 bar (reverse up to 0.4 bar)
- **Max Speed:** 15 m/s
- **Shaft size:** 15 to 120 mm

Performances shown above are minimum values for standard conditions of use; consult our technical experts for validation.

## DESIGNATION OF MATERIALS

		SELECTION FACTOR
Elastomer parts		Nitrile
		Ethylene propylene
		FPM
Seat		Porous silicon carbide
		Stainless steel
		Silicon carbide
		Alumina (99% optional)
		Tungsten carbide (option)

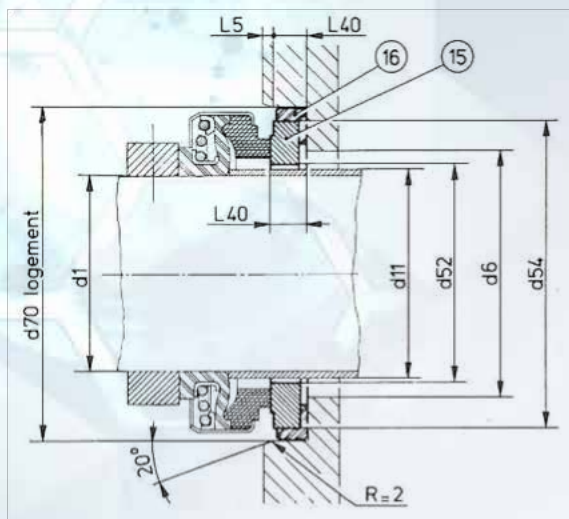

**LAR**

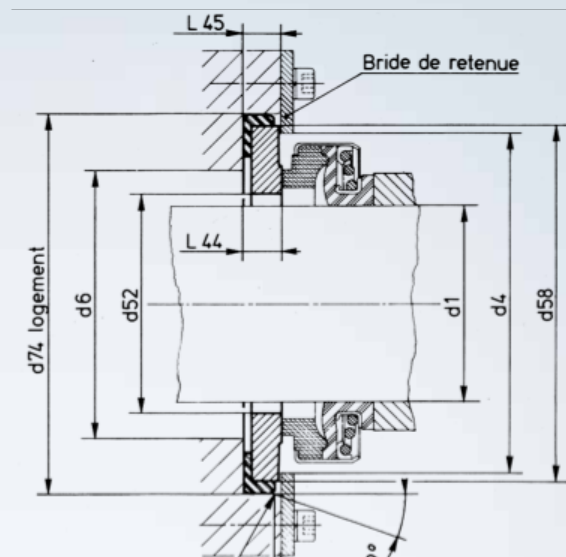

**LBR**

**DIMENSIONS OF LAR AND LBR SEALS (MM)**

Shaft diameter (D1)	SEAT (SHAFT DIAMETER – HOUSING – THICKNESS)	
	LAR (D1 – D70 – L40)	LBR (D1 – D74 – L44)
15	15-38-6	-
16	16-38-6	-
17	18-42-6	18-50-7
18	18-42-6	18-50-7
19	20-45-7	20-53-7
20	20-45-7	20-53-7
22	20-45-7	20-53-7
23	25-50-7	25-57-7
24	25-50-7	25-57-7
25	25-50-7	25-57-7
28	30-57-7	30-68-8
30	30-57-7	30-68-8
32	32-57-7	32-68-8
35	35-63-8	35-73-8
38	40-68-8	40-80-8
40	40-68-8	40-80-8
45	45-73-8	45-85-10
50	50-88-10	50-100-10
55	55-88-10	55-100-10
60	65-110-12	-
65	65-110-12	-
70	70-110-12	70-125-12
75	75-120-15	-
80	80-125-15	80-141-15
85	85-135-15	85-151-15
90	90-140-20	90-156-20
95	95-145-20	-
100	100-150-20	-
105	105-155-20	105-172-20
110	110-165-20	-
115	115-170-25	-
120	120-175-25	120-194-25