

POMPES VERTICALES ACIER INOXYDABLE VCI-M / VLI-M / VLI-A

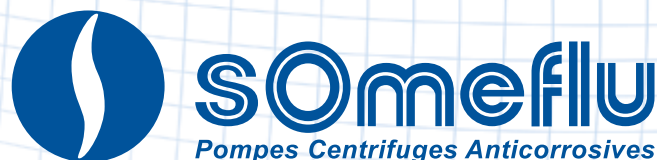

PRESENTATION

Les pompes centrifuges verticales monocellulaires VCI-M, VLI-M et VLI-A sont destinées au transfert des liquides nécessitant une construction en acier inoxydable dans les secteurs les plus divers de l'industrie.

Suivant les conditions d'implantation requises, les pompes verticales SOMEFLU s'adaptent à votre besoin :

- VCI-M longueur sous pose 200 à 440 mm suivant modèle
 - VLI-M longueur sous pose 700 à 800 mm suivant modèle
 - VLI-A longueur sous pose 600-800-1000-1100-1350-1750 mm
- Les pompes VCI-M VLI-M VLI-A offrent des débits jusqu'à 60 m³/h et une hauteur manométrique jusqu'à 30 mcl.
- Pour des performances supérieures jusqu'à 300 m³/h, voir notre série VI.

PRINCIPAUX AVANTAGES

- Moteurs normalisés CEI
- Modèle compact
- Fiabilité et robustesse grâce à la conception massive usinée et fonderie cire perdue
- Roue ouverte ou fermée
- Maintenance simplifiée
- Montage optionnel hors cuve

UTILISATIONS

- Bains de traitement de surfaces - Nickel chimique
- Bains de décapage
- Machines de nettoyage (lessive, solvants, etc.)
- Relevage d'effluents alcalins

MATERIAUX

Toutes les parties en contact avec le liquide véhiculé sont réalisées en acier INOXYDABLE.

- X3 Cr Ni Mo 17-12-2 (AISI 316L - 1.4401)
- Sur demande : X1 Ni Cr Mo Cu 25-20-5 (AISI 904L - 1.4539)

HYDRAULIQUE	JOINTS
INOX 316L	EPDM
URANUS	VITON®

CONFORMITE ATEX

Pour la zone CE, les pompes VCI-M, VLI-M et VLI-A sont disponibles en versions certifiées ATEX.

- Ex II 2/3 G/GD c IIB/IIC T4 (autres sur demande)
- Certification Volontaire INERIS 06 ATEX 3005X

CARACTERISTIQUES

Performance en 50 Hz

- De 1 à 60 m³/h
- De 1 à 30 mcl
- Température de service de -70°C à 120°C

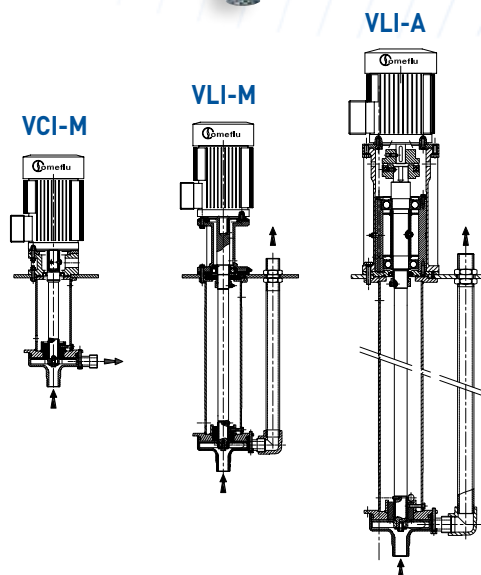
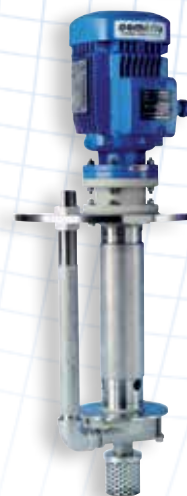

DIAGRAMMES

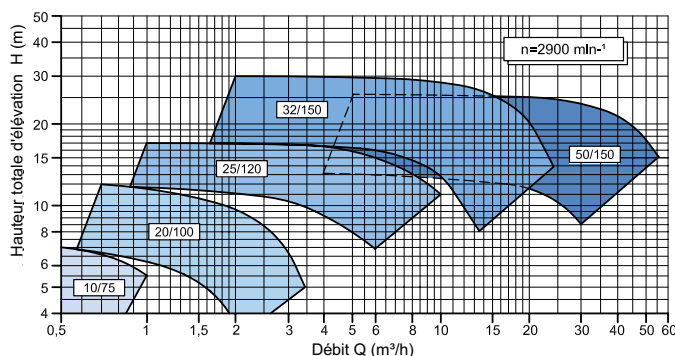
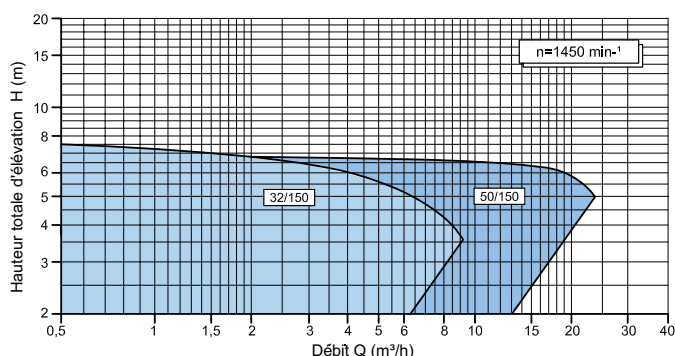

Raccordements

Fileté Bride Uniquement 50/150

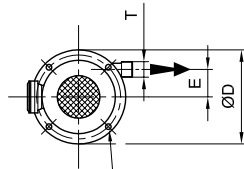
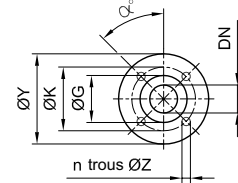
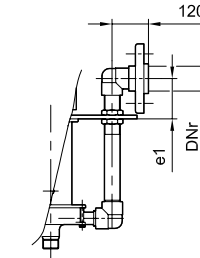
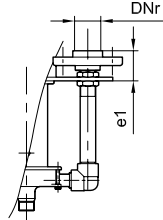
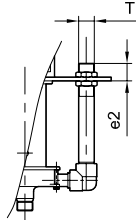
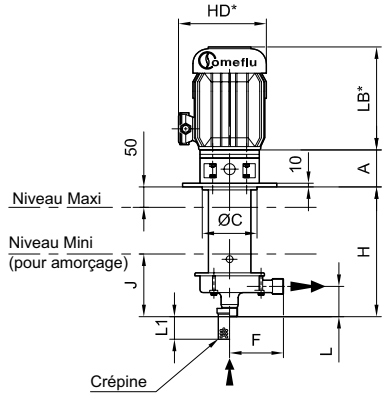

4 trous ØM
sur Ø de perçage Q

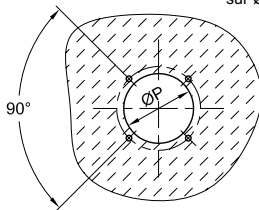
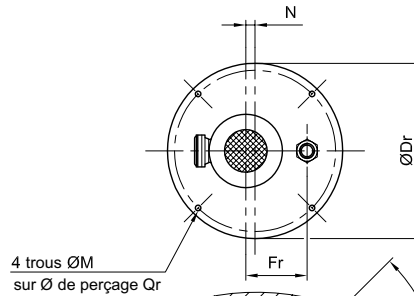

Découpe d'implantation

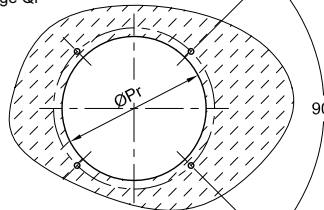

Découpe d'implantation

Types de pompes	Raccordements	
	Volute	
	Aspiration BSP-P Gaz cylindrique	Refoulement BSP-P Gaz cylindrique
10/75	1/4" Ø13 Gaz	1/4" Ø13 Gaz
20/100	3/4" Ø27 Gaz	1/4" Ø13 Gaz
25/120	1" Ø34 Gaz	1" Ø34 Gaz
32/150	1 1/4" Ø42 Gaz	1 1/4" Ø42 Gaz
50/150	2" Ø60 Gaz	2" Ø60 Gaz

Raccordements par brides tournantes ISO PN16							
DN	ØY	ØK	ØG	n	ØZ	α°	
10	95	65	34	4	14	45°	
20	105	75	40	"	"	"	
25	115	85	50	"	"	"	
32	140	100	60	"	18	"	
50	165	125	90	"	"	"	

Type	Moteur											Encombrement													
	P (kW)	Taille	LB*	A	H	J	HD*	F	L	E	ØC	Fileté			Bride (option)		Crépine (option)		Découpe						
												T	e2	DNr	e1	L1	ØD	ØP	ØM	ØQ	ØDr	ØPr	ØQr	Fr	N
10/75	0,45	2900 63M	185	65	200	90	145	66	52	33	100	1/4"	47	10	55	45	180	135	12	155	200	160	180	85	22
20/100	0,45	63M	"	"	220	115	"	90	59	43	"	3/4"	"	20	60	35	"	"	"	"	250	205	225	115	37
	1,1	80L	215	"	"	"	210	"	"	"	"	"	"	"	"	"	"	"	"	"	"	"	"	"	"
25/120	1,1	80L	"	83	300	130	"	110	70,5	50	130	1"	65	25	72	72	220	170	"	200	290	245	265	140	43
	2,2	90L	245	"	"	"	230	"	"	"	"	"	"	"	"	"	"	"	"	"	"	"	"	"	"
32/150	2,2	90L	"	88	350	145	"	130	81,5	63	148	1 1/4"	50	32	57	"	250	195	14	225	360	300	330	166	53
	3	100L	290	"	"	"	240	"	"	"	"	"	"	"	"	"	"	"	"	"	"	"	"	"	"
	4	112M	310	"	"	"	"	"	"	"	"	"	"	"	"	"	"	"	"	"	"	"	"	"	"
50/150	5,5	132S	350	106	373	170	282	130	91	55	"	2"	85	50	130	"	360	300	"	330	435	385	405	205	60
	7,5	132S	377	"	"	"	"	"	"	"	"	"	"	"	"	"	"	"	"	"	"	"	"	"	"

HD* et LB*: varient selon constructeurs

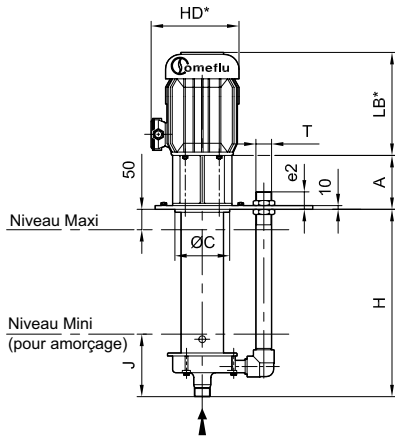

Raccordements

Bride Uniquement 50/150

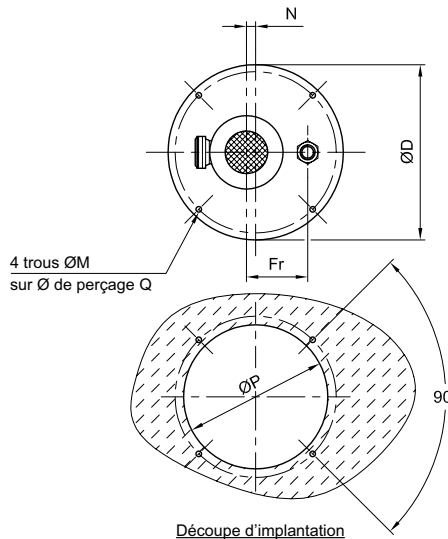
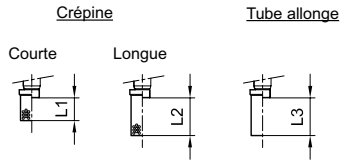
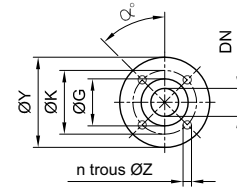
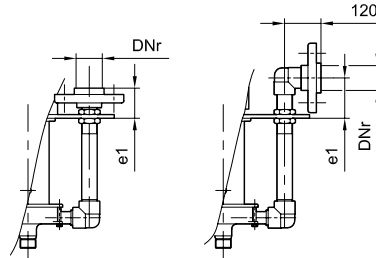

Types de pompes	Raccordements	
	Aspiration BSP-P Gaz cylindrique	Refoulement BSP-P Gaz cylindrique
10/75	1/4" Ø13 Gaz	1/4" Ø13 Gaz
20/100	3/4" Ø27 Gaz	1/4" Ø13 Gaz
25/120	1" Ø34 Gaz	1" Ø34 Gaz
32/150	1"1/4 Ø42 Gaz	1"1/4 Ø42 Gaz
50/150	2" Ø60 Gaz	2" Ø60 Gaz

Raccordements par brides tournantes ISO PN16						
DN	ØY	ØK	ØG	n	ØZ	α°
10	95	65	34	4	14	45°
20	105	75	40	"	"	"
25	115	85	50	"	"	"
32	140	100	60	"	18	"
50	165	125	90	"	"	"

Type	Moteur		Encombrement																		
	P (kW)	Taille	Fileté										Bride		Crépine		Tube allonge	Découpe			
			LB*	A	H	J	HD*	ØD	N	Fr	ØC	T	e2	(option) DNr	e1	(option) L1		(option) L2	L3	ØP	ØQ
10/75	0,45	63M	185	116	700	145	145	200	22	85	100	1/4"	50	10	55	45	**	**	160	180	12
	1,1	80L	215	"	"	"	210	250	37	115	100	3/4"	55	20	65	35	**	**	205	225	"
25/120	1,1	80L	"	163	"	170	"	290	43	140	100	1"	60	25	70	72	**	**	245	265	"
	2,2	90L	245	"	"	"	230	"	"	"	"	"	"	"	"	"	**	**	"	"	"
	3	100L	290	"	"	"	240	"	"	"	"	"	"	"	"	"	**	**	"	"	"
32/150	2,2	90L	245	176	800	180	230	360	53	166	148	1"1/4	63	32	72	"	**	**	300	330	14
	3	100L	290	"	"	"	240	"	"	"	"	"	"	"	"	"	**	**	"	"	"
	4	112M	310	"	"	"	"	"	"	"	"	"	"	"	"	"	**	**	"	"	"
50/150	5,5	132S	350	194	"	"	282	"	"	"	"	"	"	"	72	"	**	**	"	"	"
	5,5	132S	"	"	822	230	"	375	60	176	148	2"	74	50	111	"	**	**	320	345	"
	7,5	132S	377	"	"	"	"	"	"	"	"	"	"	"	"	"	**	**	"	"	"
	11	132M	385	"	"	"	323	"	"	"	"	"	"	"	"	"	**	**	"	"	"

HD* et LB*: varient selon constructeurs
 ** Longueur à la demande

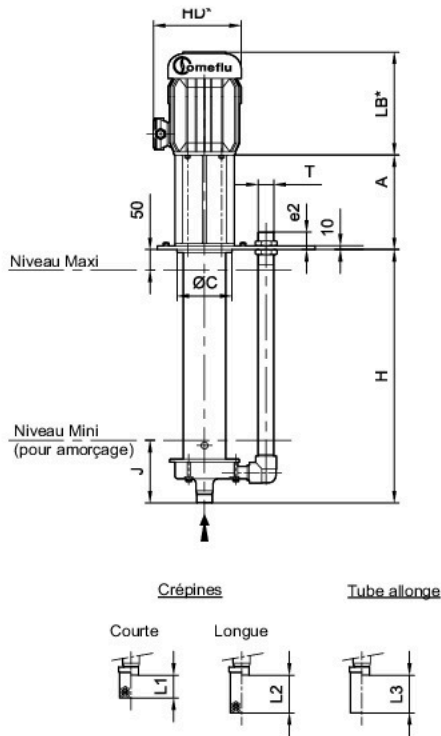

Raccordements

Bride Uniquement 50/150

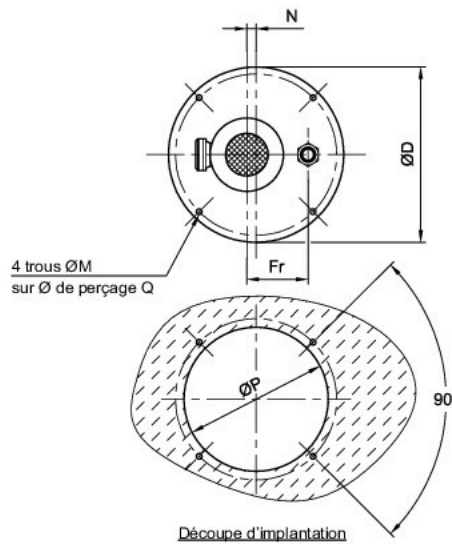
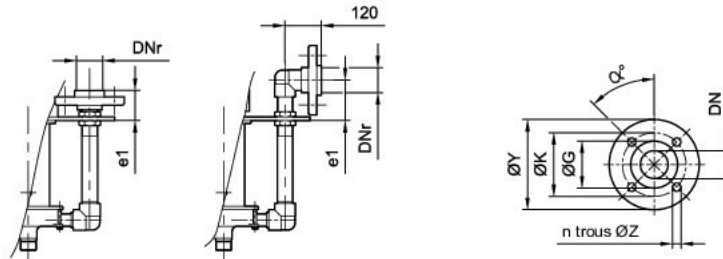

Types de pompes	Raccordements	
	Volute	
	Aspiration BSP-P Gaz cylindrique	Refoulement BSP-P Gaz cylindrique
25/120	1" Ø34 Gaz	1" Ø34 Gaz
32/150	1 1/4" Ø42 Gaz	1 1/4" Ø42 Gaz
50/150	2" Ø60 Gaz	2" Ø60 Gaz

Raccordements par brides tournantes ISO PN16						
DN	ØY	ØK	ØG	n	ØZ	α'
25	115	85	50	-	-	-
32	140	100	60	-	18	-
50	165	125	90	-	-	-

Type	Moteur		Encombrement																			
	P (kW)	Taille	Fileté										Bride		Crépine		Tube al-longe	Découpe d'implantation				
			LB*	A	H	J	HD*	ØD	N	Fr	ØC	T	e2	DNr	e1	(option)		L1	L2	L3	ØP	ØQ
25/120	1,1	1450	80L	215	335	600	165	210	360	53	166	188	1"	60	25	70	72	**	**	300	330	14
	2,2	1,1	90L	245	355	"	"	230	"	"	"	"	"	"	"	"	"	"	"	"	"	"
	3		100L	290	"	"	"	240	"	"	"	"	"	"	"	"	"	"	"	"	"	"
32/150	2,2		90L	245	345	600	165	230	360	"	166	188	1 1/4"	63	32	73	"	"	300	330	"	
	3	2,2	100L	290	355	"	"	240	"	"	"	"	"	"	"	"	"	"	"	"	"	"
	4		112M	310	"	"	"	"	"	"	"	"	"	"	"	"	"	"	"	"	"	"
50/150	5,5		132S	350	375	"	"	282	"	"	"	"	"	"	"	"	"	"	"	"	"	"
	3	3	100L	290	355	600	200	240	375	60	176	188	2"	74	50	111	"	"	320	345	"	
	4		112M	310	"	"	"	"	"	"	"	"	"	"	"	"	"	"	"	"	"	"
	5,5		132S	350	375	"	"	282	"	"	"	"	"	"	"	"	"	"	"	"	"	"
	7,5		132S	377	"	"	"	"	"	"	"	"	"	"	"	"	"	"	"	"	"	"
			132M	385	401	"	"	323	"	"	"	"	"	"	"	"	"	"	"	"	"	"

HD* et LB*: varient selon constructeurs
** Longueur à la demande